



AB28 Aeration Blower
(Right side view)

STEAM EQUIPMENT & ACCESSORIES MANUAL (SG10, SG12 & SG15) WAYNE BURNER



SG12 Steam Generator



SG15 Steam Generator



Stainless Steel
Steam Cabinet
(84" H x 67" W x 56" Deep)



Siebring Manufacturing, Inc.
303 S. Main St. PO Box 658
George, IA 51237
Ph. 888-475-3317 Fax 712-475-3490
www.siebringmfg.com



Stainless Steel
Steam Cabinet
(Door Open)



ST 2.0 Cubic Yard
Soil Aeration Cart
(Side Dump, right side)



ST 2.0 Cubic Yard
Soil Aeration Cart
(Rear Dump, Hydraulic Lift)



ST 2.0 Cubic Yard
Soil Aeration Cart
(Side Dump, side lowered)

**CONDITION OF SALE
SIEBRING MANUFACTURING, INC.
GEORGE, IA 51237**

Pursuant to Magnuson-Moss Warranty Federal Trade Commission Improvement Act P.L. 93-637, 88 STAT.2183-2193; U.P.C. 2301-2312 (Jan. 4, 1975), the following limited warranty will now replace all prior warranties issued by Siebring Manufacturing, Inc.

We warrant the equipment manufactured by us to be free from defects in material and workmanship under normal use and service, our obligation under this warranty being limited to replacing at our factory any product, or parts thereof, which shall within one year after delivery thereof to the original purchaser be returned to us with transportation (UPS Ground) charges prepaid, and which our examination shall disclose to our satisfaction to have been thus defective. We neither assume nor authorize any other person to assume for us any other liability in connection with such equipment.

“Overnight”, “Next Day” or any shipping method other than UPS Ground will be the responsibility of the customer. This warranty shall not apply to any equipment which shall have been repaired or altered outside of our factory in any way so as to affect its stability and reliability, nor which has been subject to misuse, negligence or accident, nor to any equipment, which shall have been operated beyond factory rated capacity. We shall not be liable for consequential damages caused by defective materials, equipment or parts warranted by their respective manufacturers.

Any implied warranty (including the warranty of merchantability), to the extent permitted by law, is excluded.

We will not grant any allowance for any repairs or alterations without written approval of an executive officer, and we reserve the right to make changes in design, or to make additions to, or improvements in, our products without imposing any obligations upon the company to install them on products previously manufactured.

TABLE OF CONTENTS

1. Cover
 2. Condition of Sale - Warranty
 3. Table of Contents
 4. Introduction
 5. SG10 Steam Generator
 6. SG12/SG15 Steam Generator
 7. How it Works (description)
 8. How it Works (diagram)
 9. AB 28 Aeration Blower
 10. AB 28 Aeration Blower (continued)
 11. Standard Parts
 12. Burner Specifics
 13. Burner Specifics (continued)
 14. Burner Cad Cell Eye / Nozzle
 15. Burner Pump & Pump Coupler
 16. SG10 Steam Generator Instructions - Winterizing
 17. SG12/SG15 Steam Generator Instructions - Winterizing
 18. Sterilization Trailer Instructions
 19. Pump Test / General Operating Sequence
 20. Steam Adjustment / Orifice Information
 21. SG-10/12/15 Quick Start Guide
 22. SG-10/12/15 Quick Start Guide (continued)
 23. SG-10/12/15 Quick Start Guide (continued)
 24. Shutdown Warning
 25. Delimiting the Coil
 26. SG-10/12 Electrical Diagram - ICM
 27. ICM Primary Control
 28. Century CB2034AD pump motor
 29. Marathon 5KH32GNB814X pump motor
 30. AB28 Blower Control Box Electrical Diagram
 31. McDonnell Miller Flow Switch – How it works
 32. McDonnell Miller Flow Switch – troubleshooting
 33. Agricultural Engineering Fact Sheet
 34. Agricultural Engineering Fact Sheet (continued)
 35. Agricultural Engineering Fact Sheet (continued)
- Included: Wayne Burner Manual, ICM Primary Control Instructions,
Suntec A2AV-7116 Fuel Pump, ClearWave conditioner

Soil Pasteurization

Siebring Manufacturing has designed a system which allows soil to be pasteurized. Three pieces of equipment are normally required:

- The SG10 – This steam generator produces about 300# of dry steam per hour.
- The SG12/SG15 – This steam generator produces about 500# of dry steam per hour.
- The AB28 Blower – This high pressure blower produces 400 CFM of air at 28" water column pressure.
- The ST 2.0 Trailer – This sterilizer trailer holds 2 cubic yards of material. The bottom of the trailer is made of perforated sheet steel. It is available in 2 models; Hydraulic rear dump & Drop side, side dump.

Introduction

Siebring Manufacturing has designed a system to use aerated steam to heat treat media for use by the floriculture and nursery industry. The system was designed to:

- Heat the media 100 degrees F. in 30 minutes or less.
- Add little or no water during the total process.

In an aerated system the media is heated by passing saturated air through the media to warm it by condensation heat transfer. When saturated air at 160° contacts media at 60° F., the moisture in the air condenses releasing the heat of condensation. Moisture will continue to condense until the media reaches 160° F. Large particles such as soil lumps will heat by condensation on the surface with conduction moving the heat into the lump. In a properly operating aerated steam system, a warming front about 1/2" thick will travel through the media. The leading edge will be at media temperature. The trailing edge will be the steam temperature. The media moisture content should be at the field capacity or good planting tilth for most efficient heating.

Siebring SG10 Steam Generator

- 22.5 gallon fuel capacity
- 8 hour run time
- ClearWave® water conditioner
- Reliable Wayne® Burner
- 10 inch no-flat tires



Use # 2 diesel or # 2 heating fuel only. The SG10 fuel tank holds approximately 22.5 gal. The Fuel should be clean and fresh. The consumption is 2.75 GPH or about 8 hours of run time. The SG15 has a 40 gal. capacity with a 14+ hour run time.

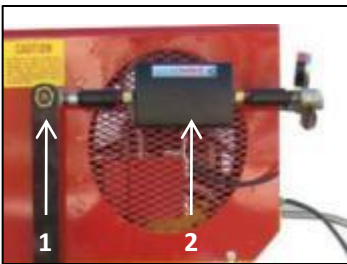

Connect the hose from the water supply to the garden hose adapter (1). The supply water should indicate 20-60 PSI at the water intake gauge. A water softener in addition to the “ClearWave”® (2) is recommended in cases of high calcium and other high mineral water conditions. **NEVER USE POND WATER OR WATER CONTAINING FERTILIZER!** Allow fresh water to flow and flush the coil after steaming for 3 – 5 minutes.

Plug the grounded electrical plug into an approved 120 volt grounded power source. If an extension cord is used, do not use a cord longer than 50’ and use at least a # 12-3 rated electrical cord. **USE CAUTION WHEN USING ELECTRICAL CORDS NEAR WATER SOURCES.** The pump motor draws approximately 4.6 amps and the burner draws an additional 3.5 amp. The pump and burner are controlled by the rotary switch on the operating panel.



The yellow handled ball valve (positioned as shown) allows cold water to discharge into the bypass pipe. As the water is heated and steam comes from this pipe after 1-2 minutes, turn the handle to the right a quarter turn and steam will go into the steam hose.

CAUTION! EXHAUST GAS TEMPERATURES ARE IN EXCESS OF 1000°F! Exhaust can be a fire hazard and can ignite combustibles up to 6 feet away. A chimney or elbow 8” in diameter can be used to direct flue gases to a safe area.





Siebring SG12/SG15 Steam Generator

- 40 gallon fuel capacity
- 14+ hour run time
- ClearWave® water conditioner
- Reliable Wayne® Burner
- 10 inch no-flat tires

Use # 2 diesel or # 2 heating fuel only. The SG15 fuel tank holds approximately 40 gal. The Fuel should be clean and fresh. The consumption is 2.75 GPH or about 14+ hours of run time.

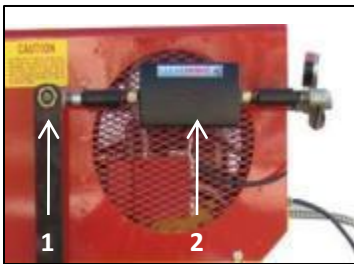
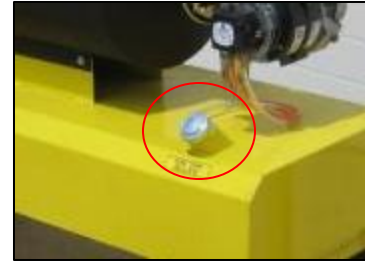

Connect the hose from the water supply to the garden hose adapter (1). The supply water should indicate 20-60 PSI at the water intake gauge. A water softener in addition to the "ClearWave"® (2) is recommended in cases of high calcium and other high mineral water conditions. **NEVER USE POND WATER OR WATER CONTAINING FERTILIZER!** Allow fresh water to flow and flush the coil after steaming for 3 – 5 minutes.

Plug the grounded electrical plug into an approved 120 volt grounded power source. If an extension cord is used, do not use a cord longer than 50' and use at least a # 12-3 rated electrical cord. **USE CAUTION WHEN USING ELECTRICAL CORDS NEAR WATER SOURCES.** The pump motor draws approximately 4.6 amps and the burner draws an additional 3.5 amp. The pump and burner are controlled by the rotary switch on the operating panel.



The yellow handled ball valve allows cold water to discharge during start/warm-up. As the water is heated and steam comes from this pipe after 1-2 minutes, turn the handle to the closed position (shown) and steam will go into the steam hose.

CAUTION! EXHAUST GAS TEMPERATURES ARE IN EXCESS OF 1000°F! Exhaust can be a fire hazard and can ignite combustibles up to 6 feet away. A chimney or elbow 8" in diameter can be used to direct flue gases to a safe area.



HOW IT WORKS / ITEM DESCRIPTION FROM PAGE 8

1. City water supply is connected using the garden hose adapter. Normal city water pressure is adequate.
2. Water passes through the “ClearWave®” water conditioner. The ClearWave Hard Water Conditioner generates a series of inaudible wave forms that affect calcium crystals in water so that they are unable to stick to anything. These “enhanced” microscopic particles then contact existing scale and cause it to loosen, break down and return into the water.
3. Water passes through the strainer. The strainer has a cleanable screen installed to filter debris from the water supply. The strainer can be disassembled and cleaned.
4. The ½” cross is installed to provide a place install the pressure gauge (item 5) and to provide troubleshooting access to the flow control (item 6).
5. Inlet Pressure Gauge. 0 – 200 PSI liquid filled gauge to indicate water supply pressure.
6. McDonnell-Miller Flow Switch. The flow switch is wired directly to the burner and prevents the burner from operating when there is no water flowing through the coils. Only the “normally open” and “common” terminals are used. Under “no flow” conditions, the connection is broken and the burner will not start. When water flow is present, the diaphragm within the control is pushed by water pressure, closing the contact, allowing the burner to start (see page 31).
7. ¼ HP 1725 RPM Pump Motor.
8. Dole Flow Regulator. At 40 – 50 PSI, the flow regulator limits the flow of water to approximately 1 gallon per minute for the SG12 or 1.5 gallons per minute for the SG15. When the flow is in excess of the desired gallons per minute the amount of water cannot be converted to steam and cooler temperatures result.
9. “ProCon” or “Fluid-o-tech” Pump - A carbon vane pump turning at 1725 RPM by the pump motor, provides positive water pressure to 100 PSI for the purpose of keeping the feed water at a higher pressure than the pressure in the coil or steam hose. Safety discharge @ 170 PSI.
10. One-way Check valve. Protects the pump by preventing the reverse flow of hot water and steam that could damage the pump.
11. Copper line to water pressure gauge.
12. Copper line to steam pressure gauge.
13. High Limit switch. Wired to the thermostat terminals on the burner’s primary control. High limit will shutdown the burner if steam temperature is excessive and reaches a temperature of 330°F (see page 30).
14. Separator Tank (SG10). The steam separator is a specially designed tank to provide dry steam for process heating and allow water condensate to be eliminated before it can get to the process heating area . The steam comes for the coil and into the top of the separator tank. The process steam is passed through the swivel fitting and ball valve, then into the steam hose. The condensate is passed to the steam trap. The SG12 and SG15’s separator tank is built into the coil.
15. Safety Pop-off. The safety pop-off will relieve steam pressure in excess of 150 PSI.
16. Copper Steam line for coil (SG10).
17. Cold water hose to coil.
18. Line to steam hose.
19. SG10 only - 3-way ball valve. As shown, valve is closed. Steam/water is vented overboard. When handle is rotated parallel with steam line, steam is directed to the appliance.
20. SG12 & SG15 only - Ball valve (not shown) located on the right, rear of the unit. Used to drain the separator and to discharge cold water during start-up.
21. Steam Trap. The steam trap is used to discharge condensate and non condensable gases with a negligible consumption or loss of live steam.
22. Overboard vent/Outlet pipe. Water is vented through this pipe during warm-up. Once the coil reaches operating temperature, steam and hot water will discharge from this pipe. For proper steaming, meter the discharge water to 9 pounds per minute of operation.

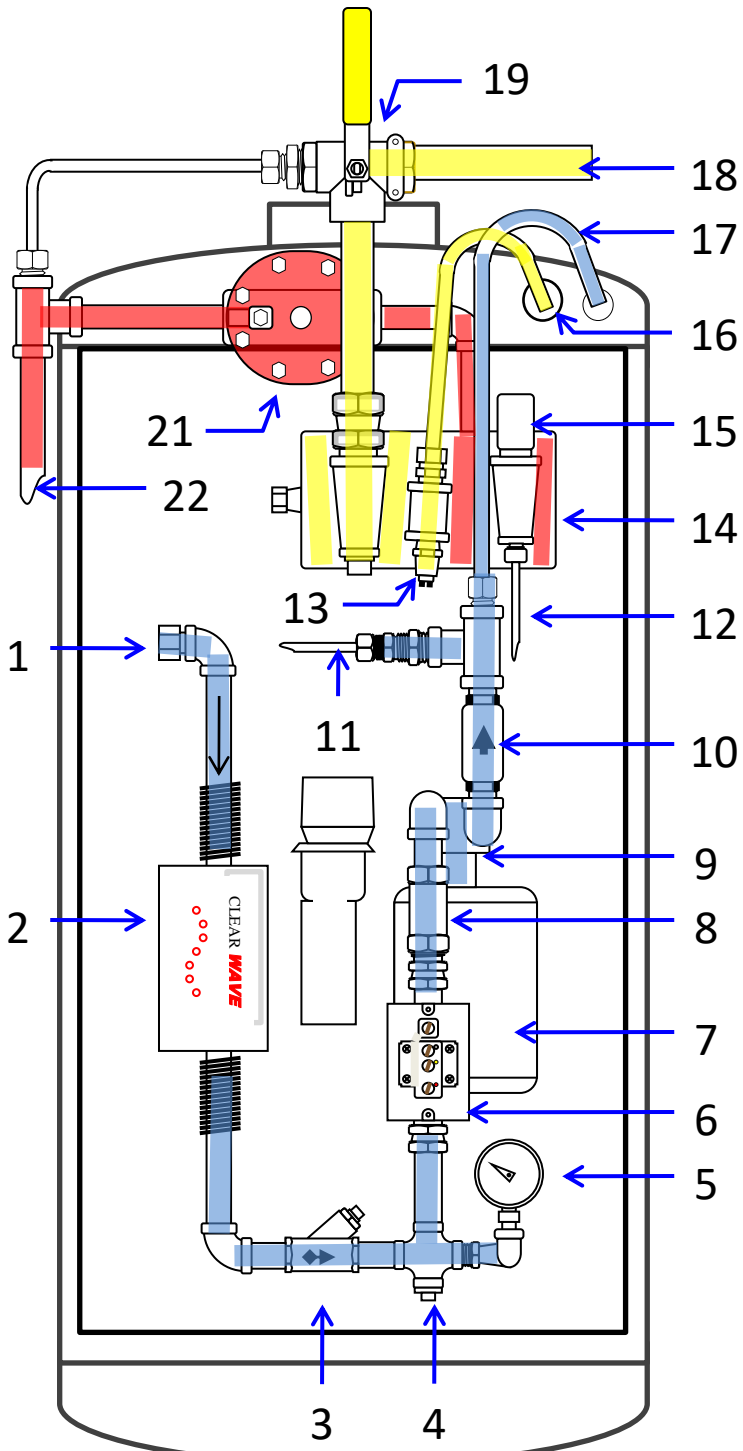

Cold Water	
Hot Water	
Steam	

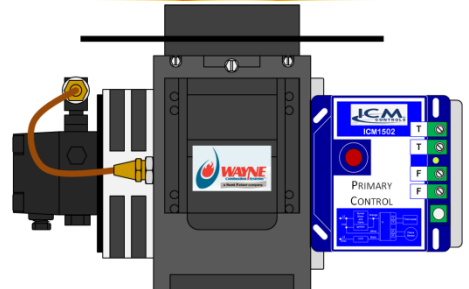
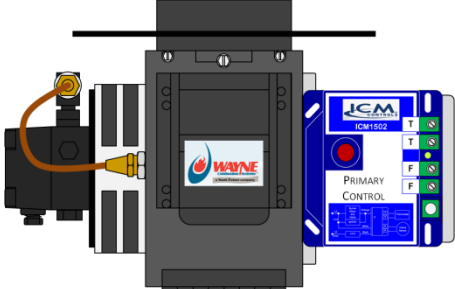
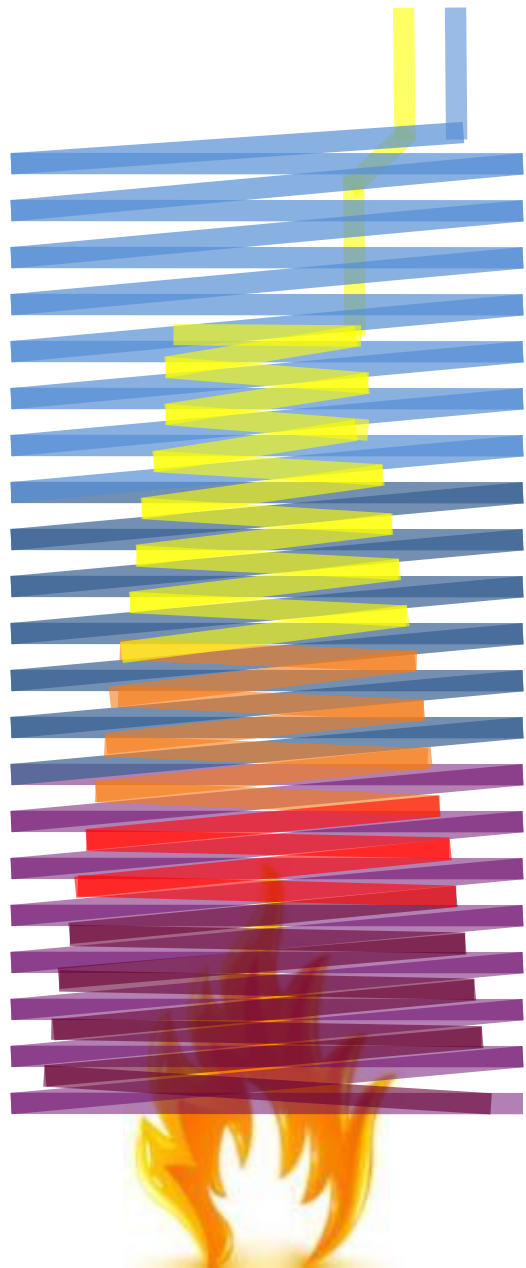

AB 28 AERATION BLOWER

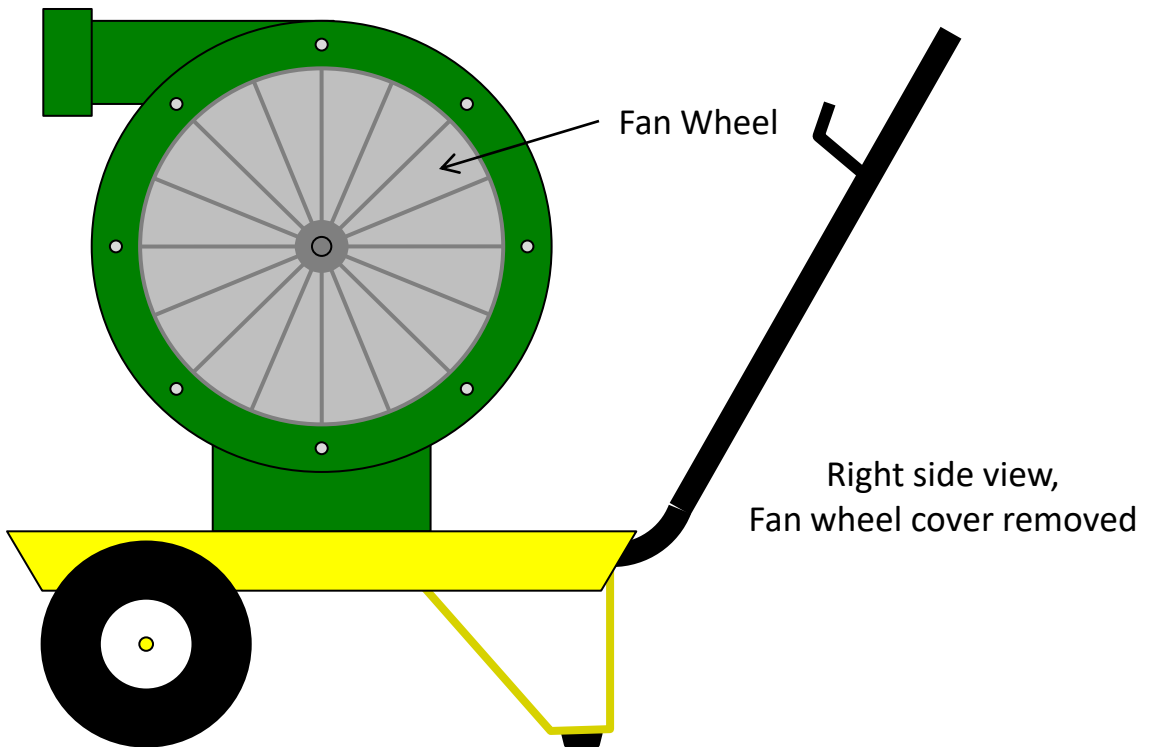
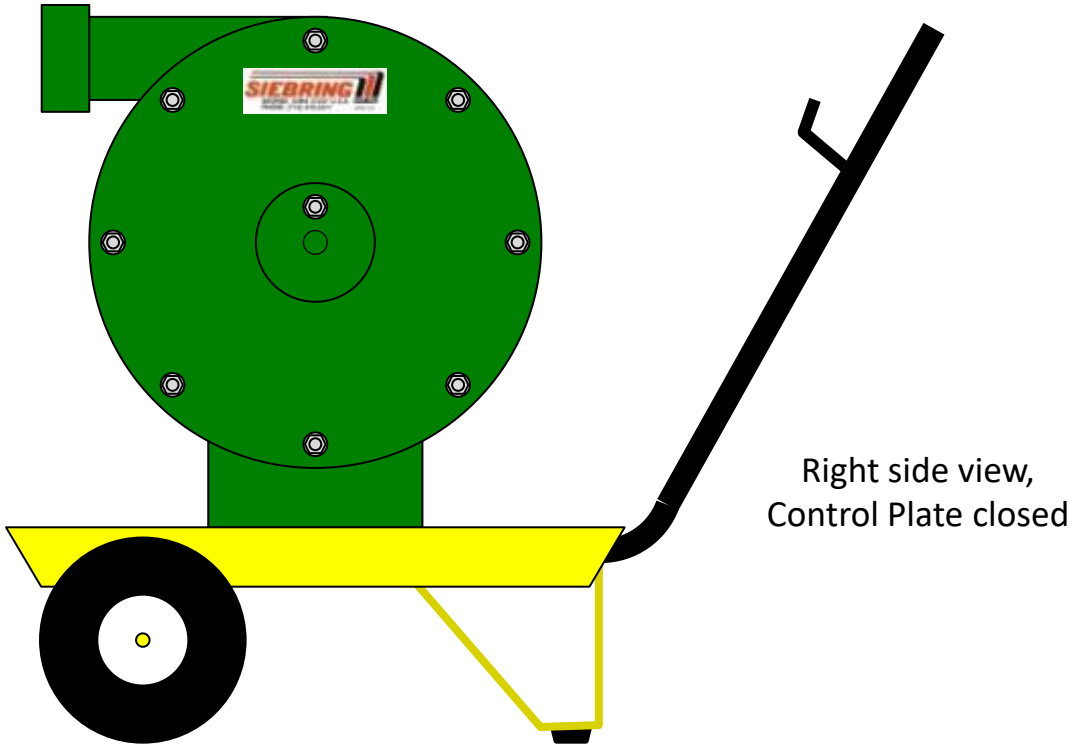

AB 28 AERATION BLOWER

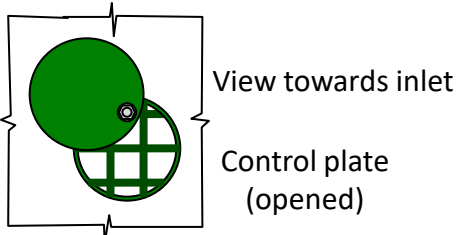
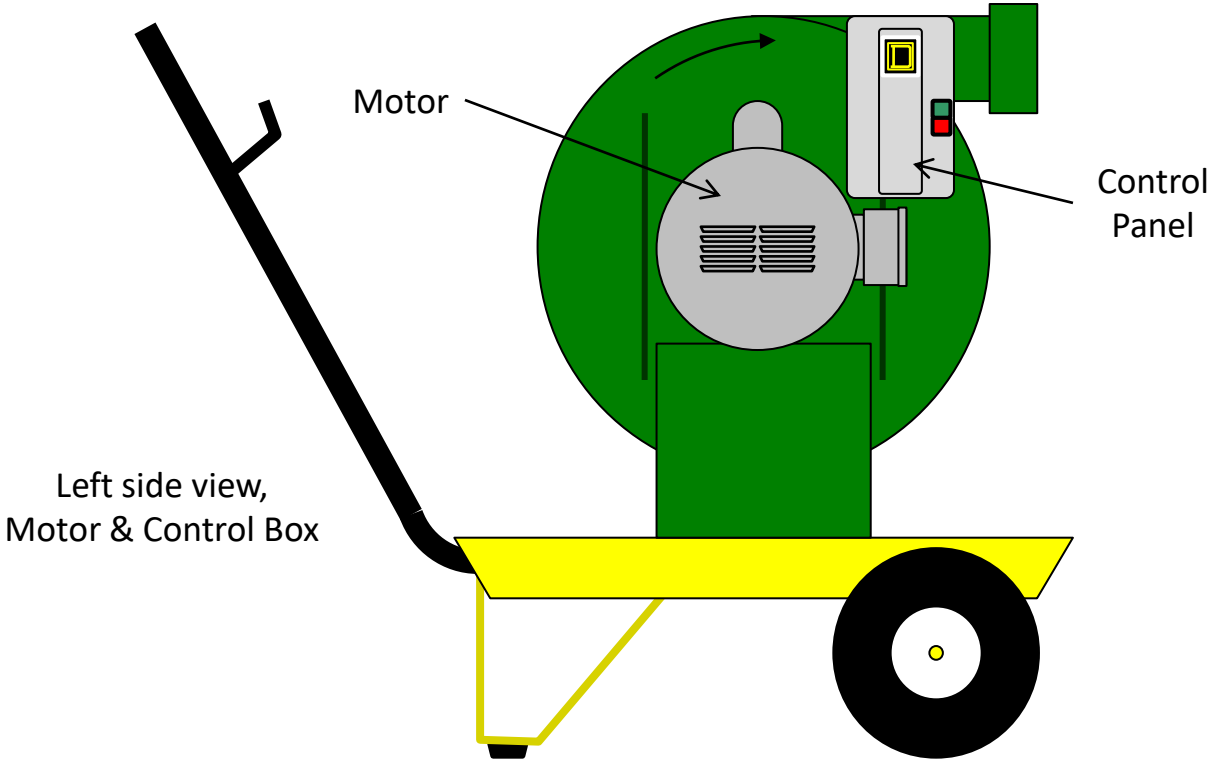

Top view

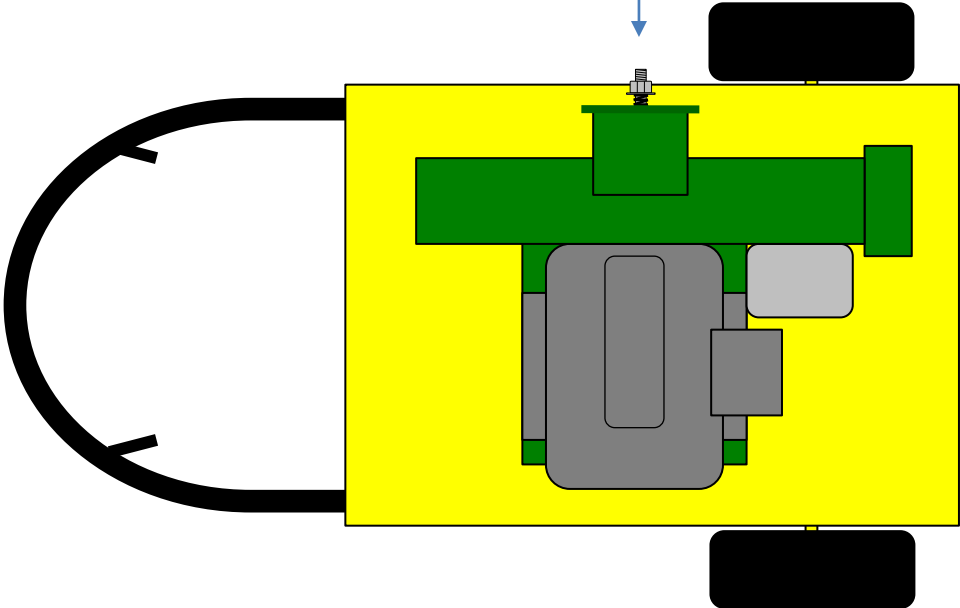

SG-10 STEAM GENERATOR STANDARD PARTS

1. Anti-freeze and de-liming hose
2. Brass air-line adapter and reducing bushing for winterizing and system blow down
3. 3/4" coupling for attaching orifices and for attaching steam hose to wagon
4. 1/4" (0.250) Steam orifice
5. 3/8" (0.375) Steam Orifice
6. 12' Steam hose standard, custom lengths available

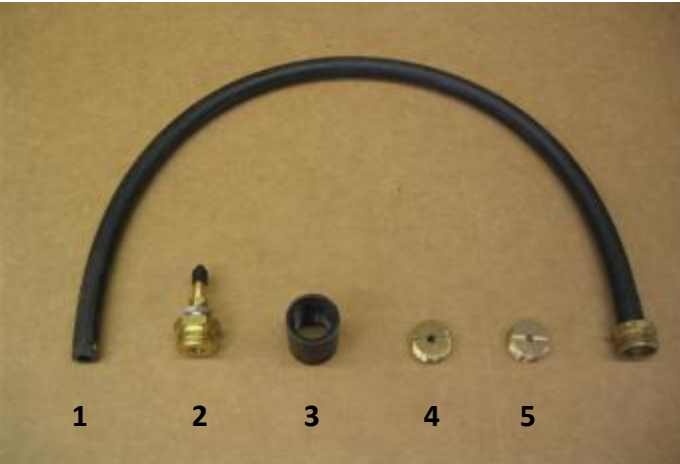

Note: Insert the appropriate orifice one half way into coupling so the hose and the attachment to the devise using the steam can be made.

SG-10,12,15 & STEAM CABINET STANDARD PARTS

1. Anti-freeze and de-liming hose
2. Brass air-line adapter and reducing bushing for winterizing and system blow down
3. 3/4" coupling for attaching orifices and for attaching steam hose to wagon
4. 1/4" (0.250) Steam orifice
5. 3/8" (0.375) Steam Orifice
6. 12' Steam hose standard, custom lengths available
7. Temperature Gauge (mounted on cabinet door)



Burner Specifics

The Wayne MSR Oil Burner

The flame retention burner uses # 2 diesel fuel. The flame looks short (12 – 14”) and medium yellow. The air tube (1.) is 5” for Siebring products. Pictured are the ICM primary control (2.), the 1/7th HP motor (3.) and the 14,000 volt ignitor (4.). The burner has a 15 sec. auto shut down if there is no fuel, flame or the cad cell eye is dirty.

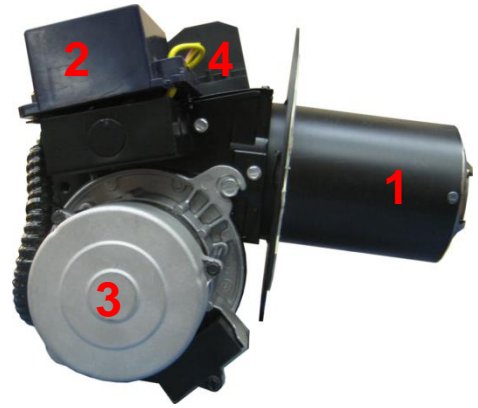

The fuel pump is factory set to 115 PSI. This insures proper atomization of the fuel. Pressure gauge fluctuations can indicated pump malfunctions, clogged or clogging fuel filters or low fuel supply.



The inner and outer air bands are set at the factory. The bands are adjustable to control the amount of combustion air that is introduced to the burner. The outer band engages the inner band at the full open or full closed positions. Smoke requires more air. Burning eyes and nose from fumes requires less air.



Accessing the burner requires removing the two top retainer screws (1/4” wrench) and loosening one side mounted (5/16” wrench) retainer screw. Lifting the ignitor will expose the oil pipe and electrodes. The 1/8” copper tube has a hex flare nut and a lock nut (below, right) for holding the oil tube in the proper position.



Electrodes are to be 1/8” ahead of the nozzle face, and 5/16” above the centerline of the nozzle orifice. See Wayne MSR manual for additional head adjustments.

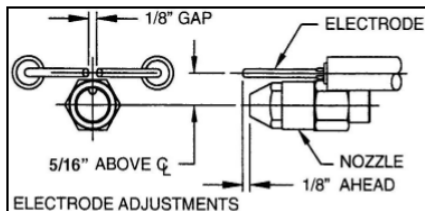
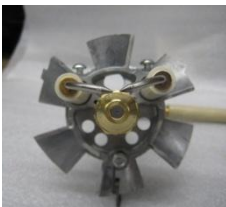

The electrodes are to be 1/8” apart.

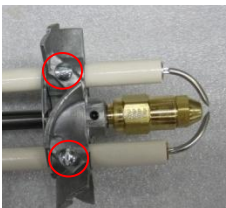

The nozzle and nozzle adapter should be tight, but not over tightened. Loosen the screws on the electrode clamps to avoid cracking the ceramic insulators when removing the fuel nozzle

Burner Specifics (continued)



The ICM primary control (above), is the standard primary control installed on Wayne burners (see page 26 & 27). It is a typical 3-wire control similar to the Honeywell 8184 in the center picture.

The “Cad Cell” terminals (bottom of 7575), normally the location of the thermostat wires, are the terminal connections for the snap disk on the SG12/15 (Genisys 7575).

Note: When purchasing a replacement primary control, please make note of the model number.

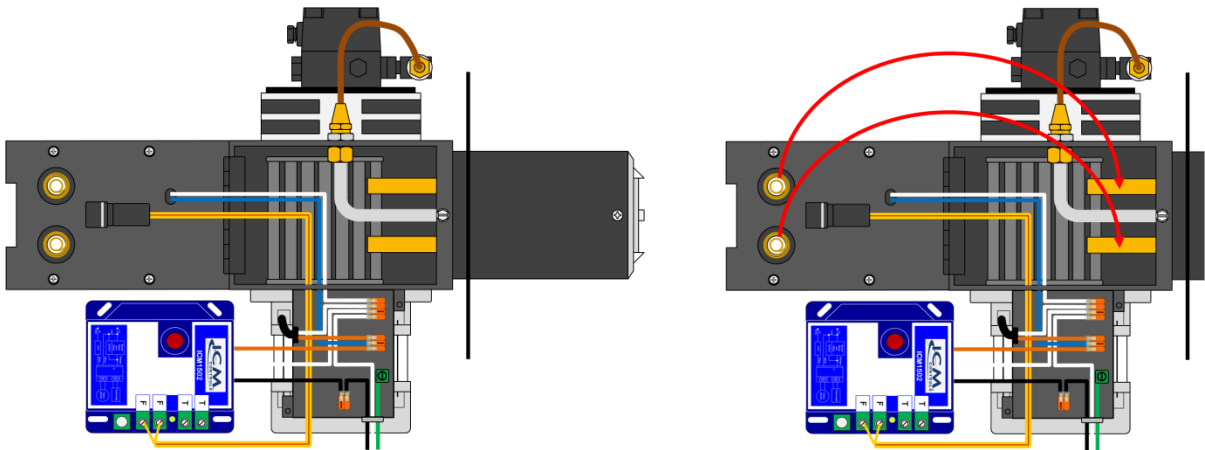

The ignitor transformer springs must contact the buss bars when the transformer is in place and secured for operation.



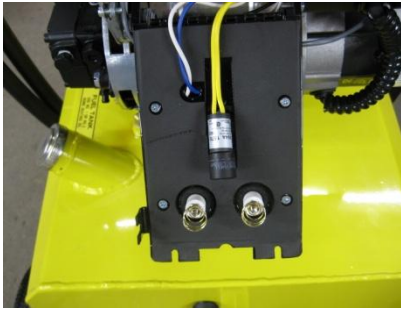

Cad Cell Eye Assembly mounted to the ignitor.



Cad Cell Eye Assembly removed from the ignitor.



Cad Cell Eye Assembly. Sensor eye unplugged from mounting socket.

The cad cell is the sensor that tells the primary control that the fire is burning and the pump can continue to pump oil. If the surface is over heated or smoked up, a false shut down will occur after 15 to 45 seconds depending on the factory set lock out time stated on the primary control. The cell must be in (No Light) before the signal to start the burner is completed. Trying to start the burner during testing of the ignitor will fail if the eye is seeing light as it will prevent the burner from starting. Disconnect one yellow lead to the cell to facilitate testing of the ignitor.

Typical SG10/SG12/SG15 Nozzle



The nozzle can be disassembled and cleaned by unscrewing the filter section. A retainer spacer and the rotor (fine grooves spin the oil) prior to going out of the orifice as a mist at 100 PSI pressure. The nozzle body is sized for the proper cone pattern for the spray and the orifice for the correct volume of oil at 100 PSI. The pattern is marked with degrees of spread such as 45 or 80 degrees. The gallons per hour are marked as .75 or 3.00 and many sizes in between. The factory installed nozzle on the SG10 2.75 GPH 80°B, 2.50 GPH for the SG12 and 2.25 GPH on the SG15.

Typical Oil Burner Nozzle



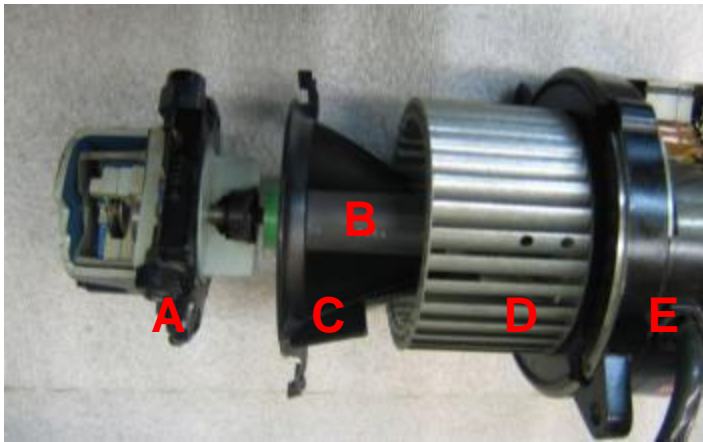

A. The fuel pump is made for #2 diesel fuel. Waste oil and other contaminants such as water can ruin the pump. **B.** The coupling is plastic and can be ruined by reverse drafts, sucking heat back through burner. **C.** Air guide directs the combustion air from the blower wheel **D.** into the blower. The air shutter controls the quality of the flame and the efficiency of the burner (shown on page 12) **E.** The burner motor is 1/7th HP, and turns at 3450 rpm. There is a thermal reset on some models. If motor over heats after cooling, depress the red reset button to restart. Two bolts mount the motor to the burner housing.

The fuel pumps are single stage. The A in the serial number is for single stage and B for two stage. This designates the vacuum lift for fuel pumping capacity, B having two gears for high lifts of fuel (see instructions). Two pipe systems require a special set screw (by-pass plug) furnished for continuous fuel flow. This eliminates air pockets in the fuel line. The plug for removal to install the set screw is on the under side of the pump. See diagram on page 9 and the instructions on the white pump label. The pump has a strainer **F.** that should be cleaned periodically. Access the strainer by removing 4 hex drive screws **G.** from the pump cover.

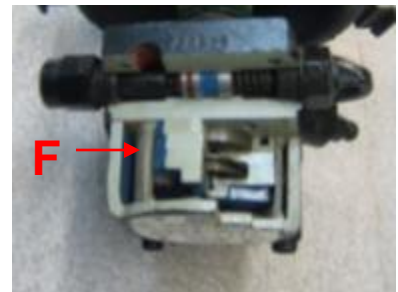

Pump couplings **B.** join the motor and fuel pump as a common drive for the blower and pump. The couplings are made of plastic and heat will damage the body of the coupling when down back drafts occur. The end for the pump is smaller and larger for the motor. The correct length for each pump manufacturer is different but can be cut to length. Deformed couplings fold up and cause burner failure. Exhaust fans in a room are the biggest cause of the back flow of heat in greenhouses. The air guide **C.** is a source of problems when the reverse draft causes it to be deformed and rub on the blower wheel. Failure to replace a deformed air guide will cause flame and combustion problems when the unit is not in place. Replace any deformed parts.

Instructions for SG10 Steam Generator

1. Check the free flow of water from the steam hose. 1 min. = 1.0 gallon.

Note: For inadequate water flow check:

- A. Clogged strainers
- B. Limed hose fittings in steam line, from separator tank to discharge hose.
- C. Defective pump (see page 19 for pump test procedure)
- D. Insufficient water pressure inlet. (40 to 70 psi is OK)
- E. Check for clogged flow control (Dole) in the pump intake line, 1 1/2 gpm. 3 small holes in the rubber disk in Dole flow control supply may clog.

2. To start for steam:

- A. Turn on pump switch.
- B. Turn on burner switch.
- C. Allow steam to come up to operating pressure. (This time may vary with the fuel used.)
- D. Operating pressure averages should not exceed:
 - Water pressure at gauge - 40 - 50 PSI
 - Steam discharge pressure - 50 - 75 PSI

3. If liming of the coil is a noticeable problem , see 25 page for procedure to follow for correction.

4. For oil burner trouble shooting , see Beckett manual for procedures.

5. Freeze protection procedure:

- A. Using short hose provided, attach it to the water inlet side of the pump.
- B. Prepare a 50/50 mix of antifreeze (rated to protect against lowest predicted ambient temperature).
- C. Energize pump and allow 2 quarts of anti-freeze to be pumped into the coil.
- D. Disconnect the short section of hose.
- E. Attach high pressure air stem adapter.
- F. Apply adequate high pressure air to blow water and antifreeze out of the discharge hose.

Steam separator tank protection:

Open drain valve on the lower side of the steam separator tank.

Instructions for SG12 & SG15 Steam Generator

1. Check the free flow of water from the steam hose. 1 gal. in 1 minute for the SG12 and 1.5 gallon in 1 minute for the SG15.

Note: For inadequate water flow check:

- A. Clogged strainers
- B. Limed hose fittings in steam line, from separator tank to discharge hose.
- C. Defective pump
- D. Insufficient water pressure inlet. (40 to 70 psi is OK)
- E. Check for clogged flow control (Dole) in the pump intake line, 1 1/2 gpm. 3 small holes in the rubber disk in Dole flow control supply may clog.

2. To start for steam:

- A. Turn on pump switch.
- B. Turn on burner switch.
- C. Allow steam to come up to operating pressure. (This time may vary with the fuel used.)
- D. Operating pressure averages should not exceed:
 - Water pressure at gauge - 40 - 70 PSI
 - Steam discharge pressure - 60 - 90 PSI

3. If water pressure is much higher than the steam pressure, the coil is beginning to clog. If liming of the coil is suspect , see 25 page for procedure to follow for correction.

4. For oil burner trouble shooting , see Beckett manual for procedures.

5. Freeze protection procedure:

- A. Using short hose provided, attach it to the water inlet side of the pump.
- B. Prepare a 50/50 mix of antifreeze (rated to protect against lowest predicted ambient temperature).
- C. Energize pump and allow 2 quarts of anti-freeze to be pumped into the coil.
- D. Disconnect the short section of hose.
- E. Attach high pressure air stem adapter.
- F. Apply adequate high pressure air to blow water and antifreeze out of the discharge hose.

Steam separator tank protection:

Open drain valve on the lower side of the steam separator tank.

ST 2.0 STERILIZATION TRAILER

General Instructions:

These trailers have been designed to facilitate pasteurizing soil mixes. ALWAYS load the trailer to a uniform height of soil. Depending upon the weight and type of soil mixture, the trailer may not be completely filled. Some experimentation may be required to determine the best loading depth. The soil mixes should not have any large chunks etc. in it. The cover must be in place when aeration blowers are in use.

WARNING: Do not get any portion of your body under the dirt box while it is moving or in an elevated position.

WARNING: Servicing the box or pump with the box in an elevated position is dangerous. Always engage the box elevation safety leg before working on pumps, hoses, or electrical systems.

Operating Tips:

- Check the tire inflation prior to loading.
- Always block wheels prior to unhooking full trailers from a tractor or pulling device.
- Drain plugs are for excess water removal, but should be in place during the steaming of the trailer.
- Use the smallest amount of aeration air, driving the steam through the soil during the heating of the soil mix.
- Full air can be applied during cool down of soil mix.

Two Models Available:

Side Unloading Box – This unit is equipped with sides that can be lowered to provide work benches.

Rear Unloading Box - (with battery operated hydraulic lift). This unit requires a Group 27 Marine Battery. **MARINE BATTERY ONLY.**

To test ProCon or Fluid-O-tech pumps:

1. Locate the “Tee” fitting and disconnect the hydraulic hose going to the coil
2. Install $\frac{3}{8}$ ” pipe plug in place of the hydraulic hose.

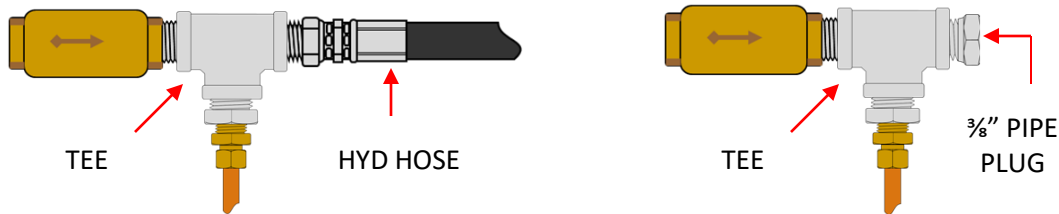

3. Connect water source and turn on
4. Turn pump on and read gauge pressure
5. Pressure should indicate 100 PSI or more. Less than 100 PSI – replace pump

General Operating Sequence

1. Fill the cart with media. (Use reasonable care to distribute the material evenly).
2. Connect the air and steam hoses to the cart.
3. Start the steam generator. (Be sure water supply is connected with the valve open).
4. Start the blower. (Set the air volume control to get the desired treatment temperature).
5. Operate the steam generator continuously until the exhaust air reaches the treatment temperature.
6. Reduce the steam generator flow and the blower flow to keep the media at temperature for approximately 30 minutes.
7. Stop steam flow. Continue fan at maximum output until the media is below 100° F.
8. Shut off the blower, the media is now ready for use.

IMPORTANT!

STEAM PRESSURE ADJUSTMENT FOR DELIVERY OF DRY STEAM

FOR CORRECT OPERATION THIS STEAM GENERATOR MUST DEVELOP STEAM PRESSURE.

BACK PRESSURE IS GENERATED BY THE USE OF A BRASS ORIFICE. THE SIZE OF THE HOLE IN THE ORIFICE DISK DETERMINES HOW MUCH PRESSURE THE SYSTEM WILL GENERATE.

STEAM HOSE OUTLET ORIFICE CHART

ORIFICE SIZE (INCH)	ORIFICE SIZE (DECIMAL)	WEATHER CONDITIONS	STEAM PRESSURE
5/16 INCH	0.3125	HOT WEATHER	40-45 PSI NORMAL
3/8 INCH	0.375	WARM WEATHER	70-80 PSI NORMAL

CAUTION! STOP IMMEDIATELY IF PRESSURE BUILDS BEYOND PRESSURES SHOWN ABOVE!!

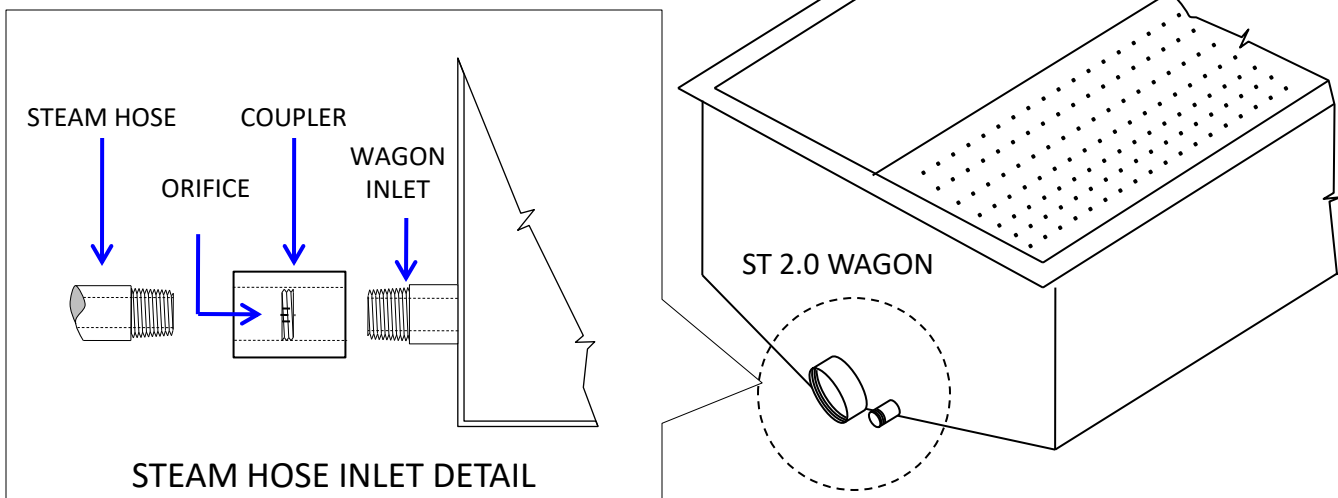

SG10/SG12/SG15 Steam Generator Quick Start Guide



1. Watch Instructional Video two times.
2. Siebring recommends # 2 fuel with API weights of 32 – 36 if available. If newer, low-sulfur blend fuels are used, fuel pump pressure should be set at 125 PSI.
3. Connect water source to $\frac{3}{4}$ " garden hose fitting on Steam Generator and turn on.
4. Connect to 120V AC power.
5. SG10 - Move steam/overflow ball valve to steam position. Allow water to circulate completely through the machine until clear water is discharged, approx. 3 minutes.
6. SG12/SG15 - Move the ball valve to the open position until clear water is discharged, approx. 3 minutes.

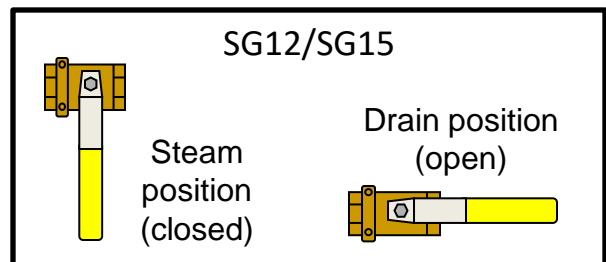
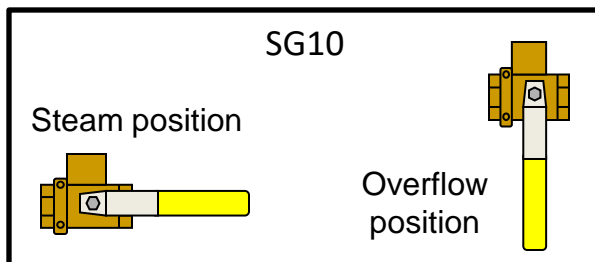

7. Connect steam hose to steam generator.
8. Install or confirm installation of the appropriate brass orifice in steam hose coupler (refer to manual or video). Steam will transfer the most heat at the pressure drop area, so the orifice must be installed in the steam hose to provide sufficient back pressure the entire length of the steam hose, allowing the pressure drop to be as close to the media as possible. The orifice should be installed approximately half-way into the coupler to allow hose and appliance connections on either end.

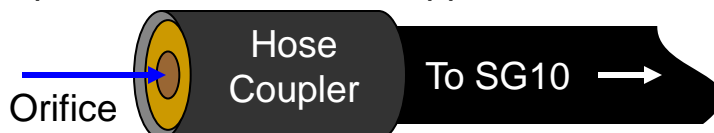

8. At start-up, check for free flow of water from steam hose.
9. With the control switch in the “Pump” position, regulate water flow to achieve the proper weight per minute at the orifice end of the steam hose, 9 lbs for SG12 & 12 lbs for SG15.



10. Connect steam hose to sterilization device.
11. Position 3-way ball valve to overflow (SG10). On the SG12/15 the valve will remain in the drain position
12. Move control switch to “Burner” position. Pump will continue to run, Beckett burner will start after a short delay.
13. After a 2 – 3 minute warm-up, and a generous amount of steam is discharging from the overflow, position the ball valve to the steam position

Shutdown:

1. Move control switch to “Pump” position, burner will shut off, pump will continue to run.
2. Continue to pump clear water thru pump & coil until all traces of steam have dissipated and discharge water is starting to cool. Complete flushing of the coil will prevent liming and extend the life of the coil.
3. Turn control switch to “Off” & turn off source water.
4. Disconnect steamer from sterilization device, disconnect source water & AC power

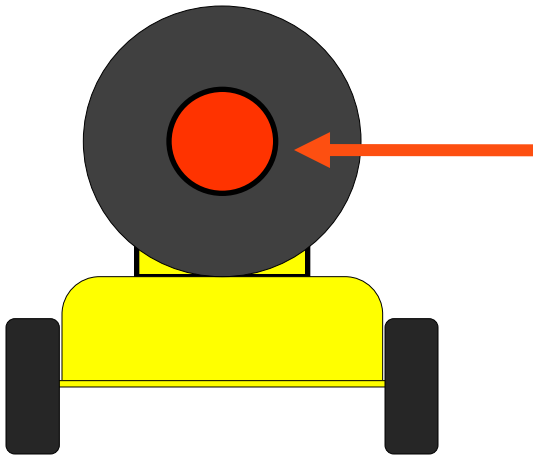

Exhaust gas temperatures can be in excess of 1100° F

Notes:

	<u>SG10</u>	<u>SG12/SG15</u>
-Input water pressure	45 PSI optimum	45 PSI
-Water Pressure (gauge)	40 - 50 PSI	40 – 70 PSI
-Steam Discharge Pressure	50 - 75 PSI	60 – 90 PSI
-Steam Temp at coupling (orifice)	200° F	290° / 300°
-If available, 32 – 36 API weight # 2 diesel fuel should be used. If using newer, low sulfur blend fuels, increase pump pressure to 125 PSI		
-Temp Sensor will shut down machine if steam temp exceeds 325° F (163°C)		
-Rising steam pressures may be indication of lime deposits		

Steam hose to SG10

Hose Coupler

Wagon Inlet

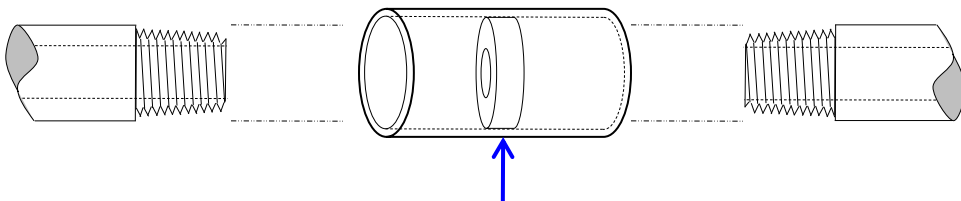

Orifice

Screw orifice approximately
halfway into coupler



ATTENTION!

IMMEDIATELY AFTER SHUTDOWN, ALLOW COOL, CLEAR WATER THRU PUMP & COIL UNTIL LIME DEPOSITS ARE COMPLETELY FLUSHED OUT AND ONLY CLEAR WATER RUNS OUT OF THE DISCHARGE OF THE COIL.

DELIMING INSTRUCTIONS FOR HOT WATER/STEAMER COILS

**** CAUTION: DO NOT USE THIS PROCEDURE ON A COIL THAT IS COMPLETELY PLUGGED!****

WARNING: Wear proper Personal Protection Equipment (PPE) Face mask, apron & gloves

1. Disconnect the steam generator from wagon or cabinet.
2. Select either **Dosa-Klean** water system cleanser or **muriatic acid** to clean the coils. Naturally occurring minerals, metals and microbes may differ from one location to the next. Only experimentation will determine which method is more effective for your type water. For Dosa-Klean, follow the mixing directions on the package. For muriatic acid, follow the steps 3 - 9 below. Mix enough solution to make at least 10 gallons.

**** CAUTION: ALWAYS ADD THE ACID TO THE WATER, NEVER THE WATER TO THE ACID****

3. Put 10 gallons of water in a plastic container, into this, **very slowly** add 1 gallon of muriatic acid. 10 parts water to 1 part muriatic acid. 10 gallons or more preferred.
4. Connect a length of garden hose or the de-liming hose and adapter and enough hose to reach into your solution vessel, to the water inlet. This will be your intake hose. To reduce the chances of sucking up lime and debris, keep the intake hose well off the bottom of the container.
5. Connect the steam hose or equivalent to the steam outlet and place the end into your container. This will be your return line.
6. Allow to circulate for 2-3 hours.
7. Immediately after de-liming, connect regular water supply and flush the coil with clear water for approximately 15 minutes.
8. De-liming solution may be stored and reused.

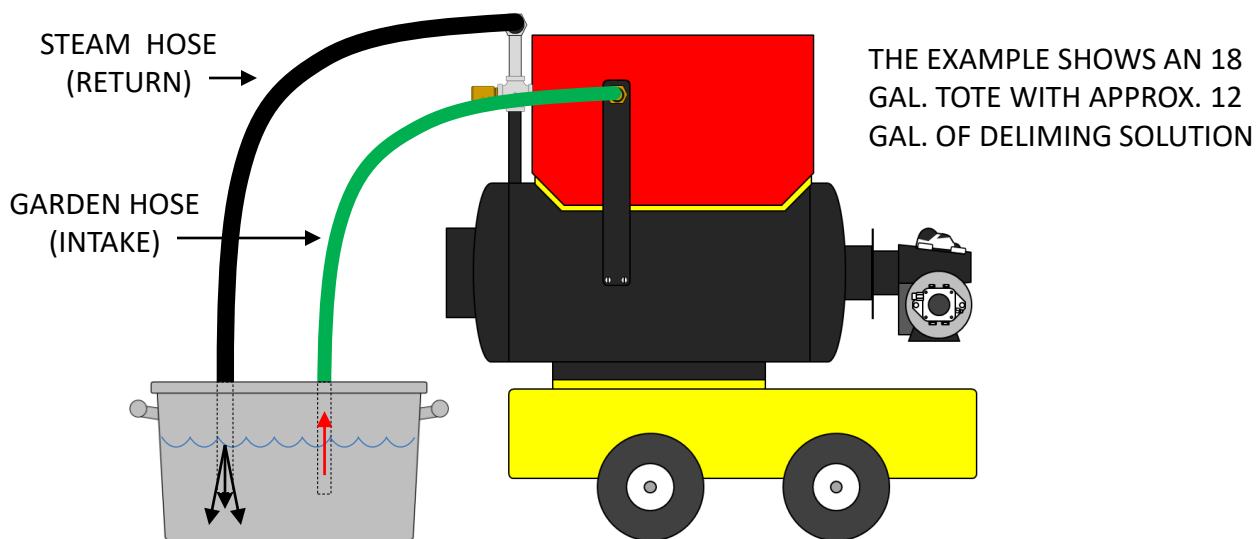

TO PREVENT THE INTAKE HOSE FROM SUCKING UP LIME AND DEBRIS, DO NOT ALLOW INTAKE HOSE TO CONTACT THE BOTTOM OF THE SOLUTION VESSEL

Wayne MSR Burner

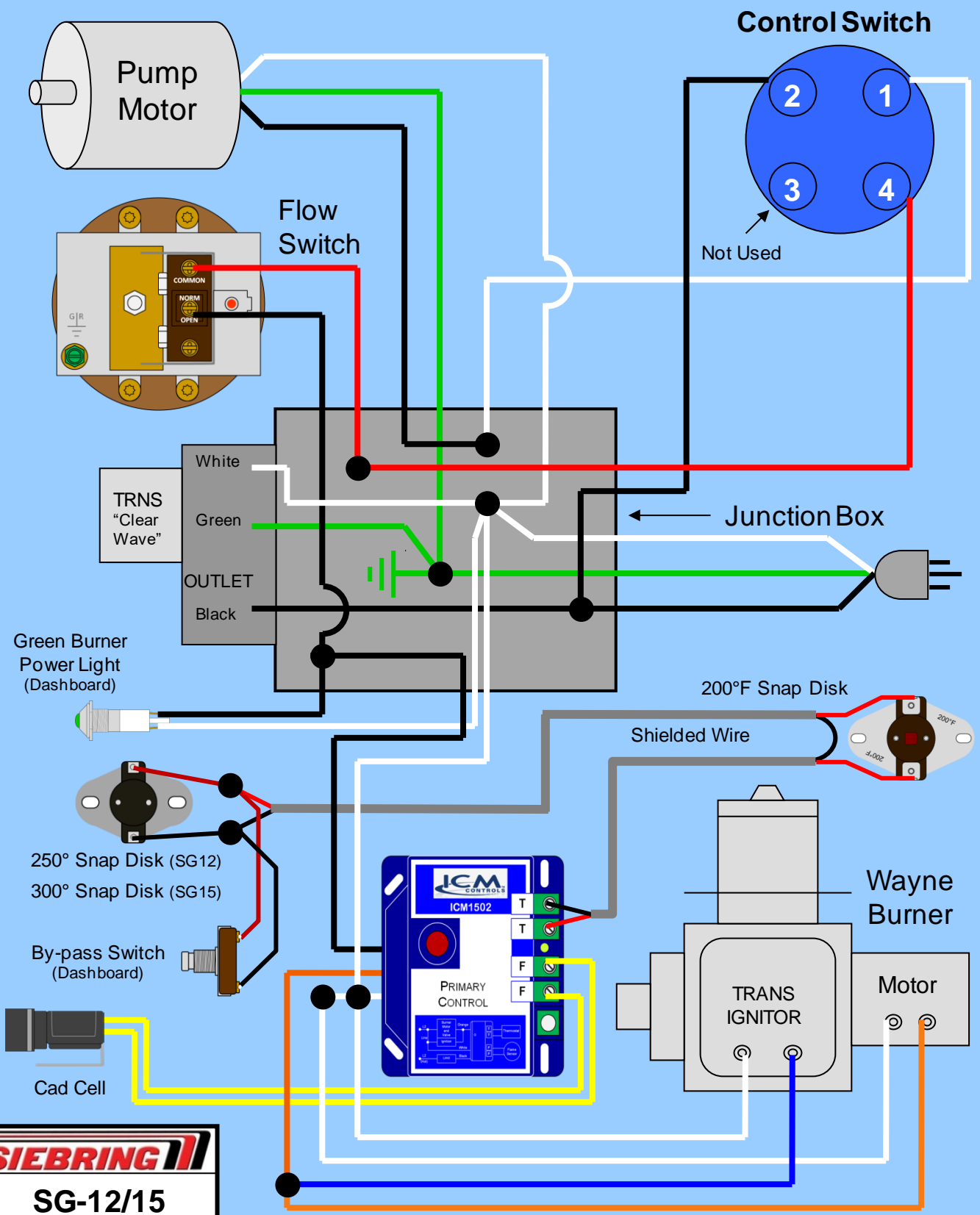

SIEBRING	
SG-12/15	
ELECTRICAL DIAGRAM	
11-1-17	D Hollander

This diagram is applicable to steam generators built on or after 11-1-17.

WAYNE MSR OIL BURNER SG12/15

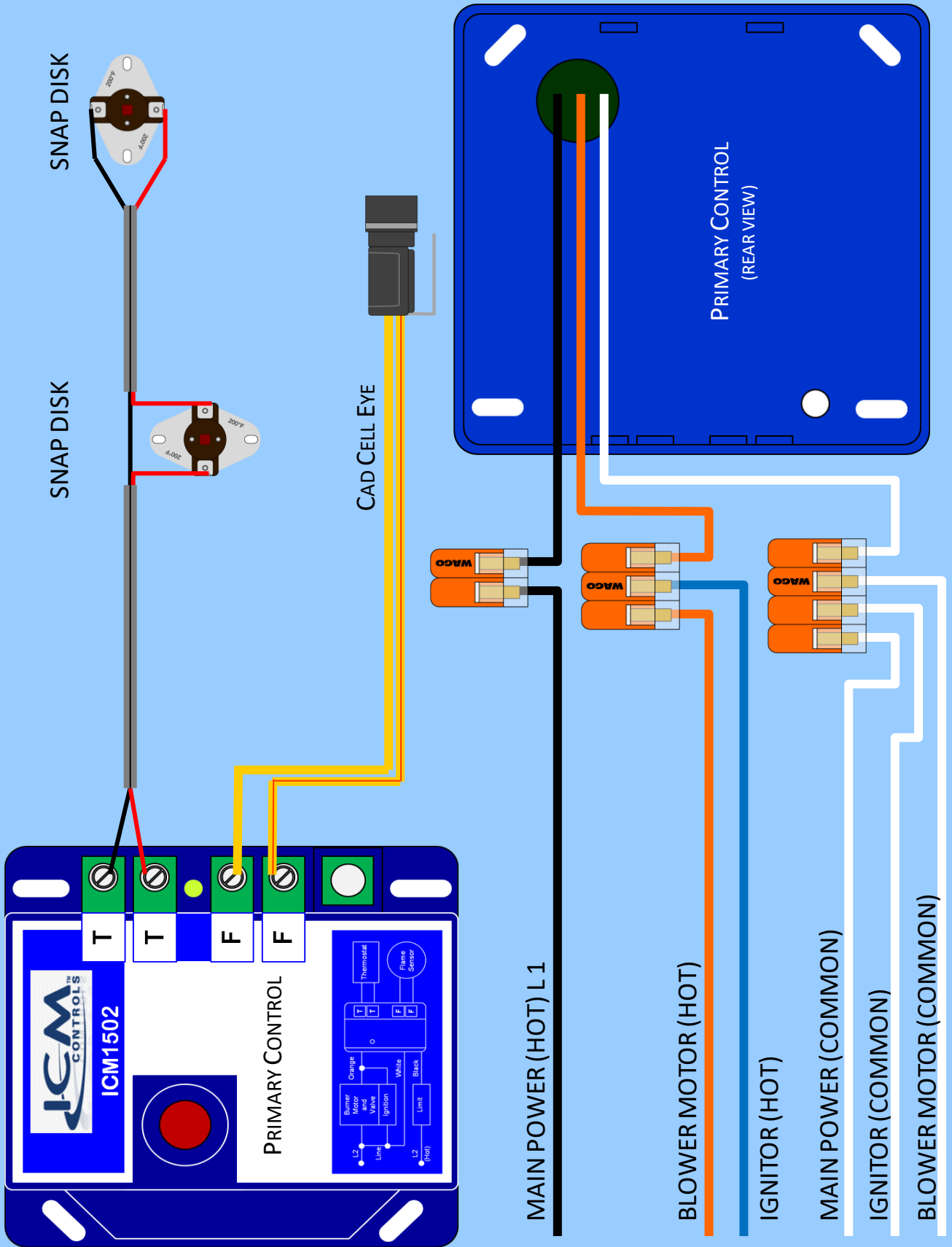

CENTURY CB2034AD STEAM GENERATOR PUMP MOTOR

115V CCW ROT.

230V CCW ROT.

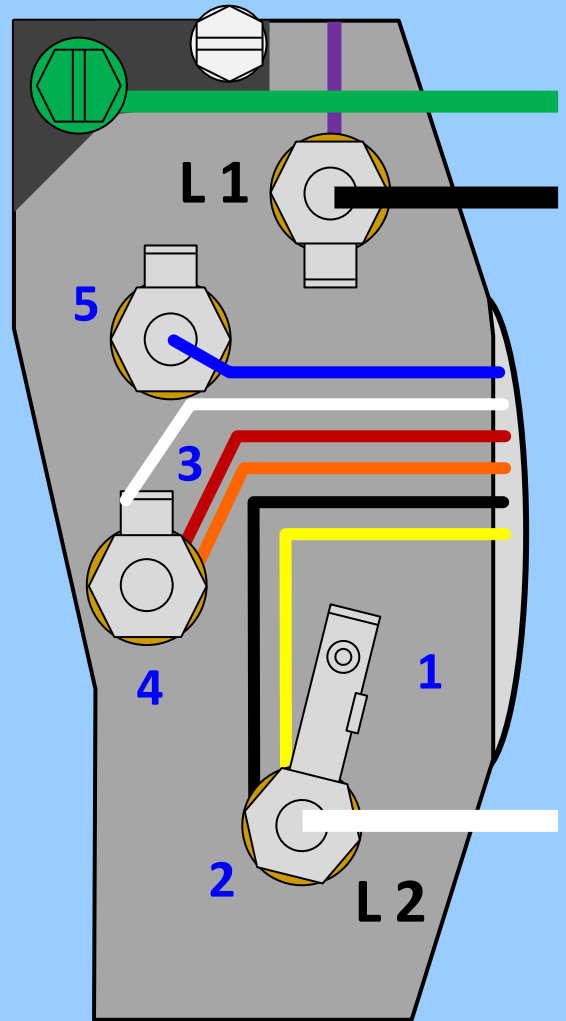
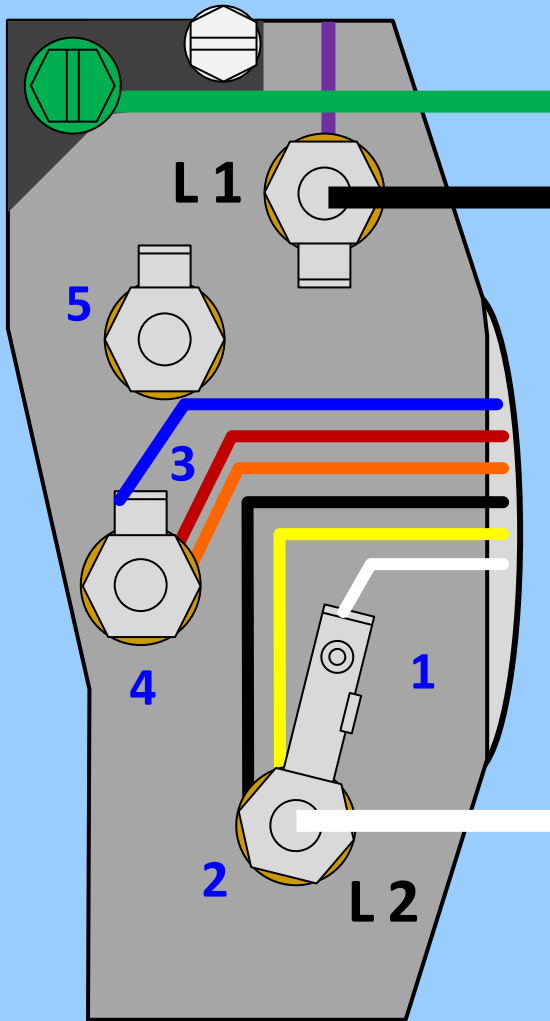

- CONNECTIONS:**
- 5
 - RED — ○ 4
 - BLUE — ○ 3
 - BLACK — ○ 2
 - WHITE — ○ 1
 - L1 ○ — HOT (BLACK)
 - L2 ○ — COMMON (WHITE)

115V CCW ROTATION SHOWN;
 FOR 230V – CONNECT BLUE TO 5 &
 WHITE TO 3, FOR CW ROTATION,
 INTERCHANGE RED & BLACK

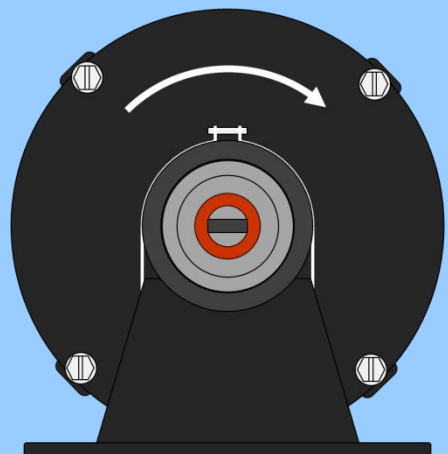

MOTOR MUST TURN CLOCKWISE AS
 VIEWED FROM PUMP DRIVE SHAFT END

MARATHON 5KH32GNB814X STEAM GENERATOR PUMP MOTOR

115V CCW ROT.

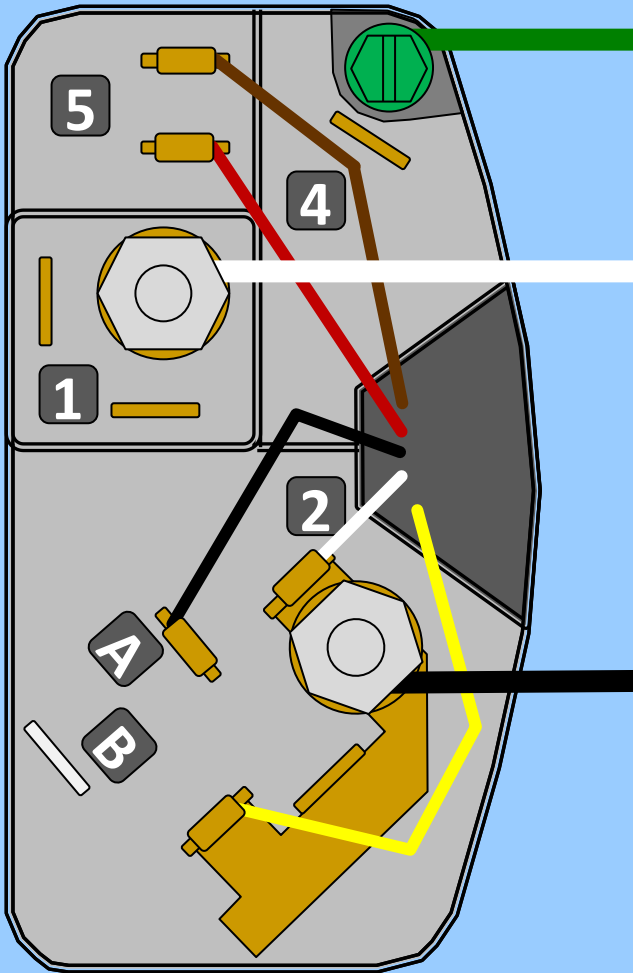

230V CCW ROT.

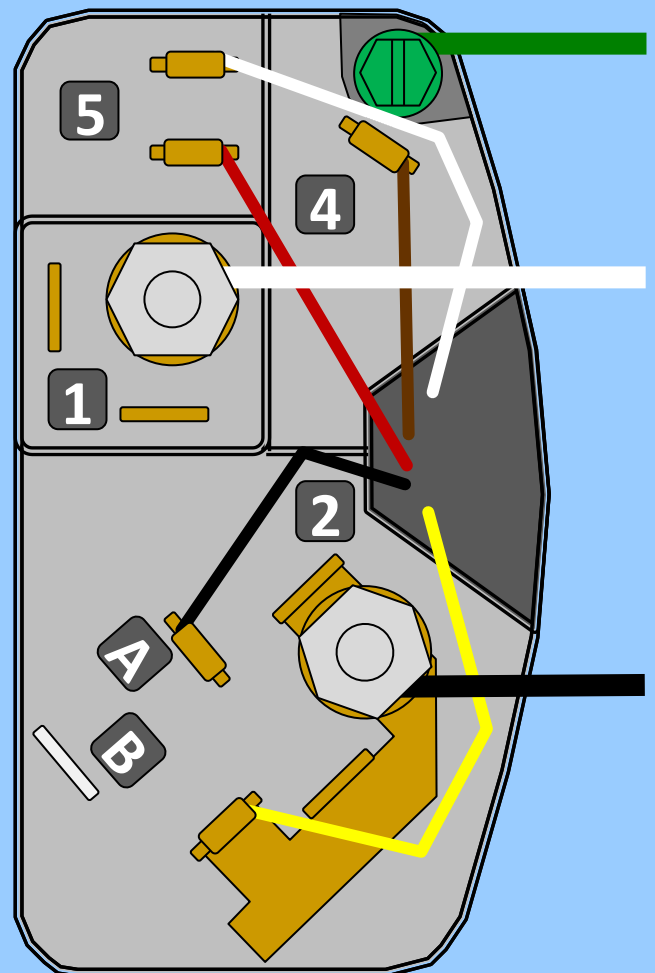

VOLTAGE CONNECTIONS

LEAD	LOW VOLT	HIGH VOLT
BROWN	5	4
WHITE	2	5
RED	5	5
BLACK	A	A

CCW ROTATION AS SHOWN,
TO REVERSE ROTATION
INTERCHANGE BLACK & RED

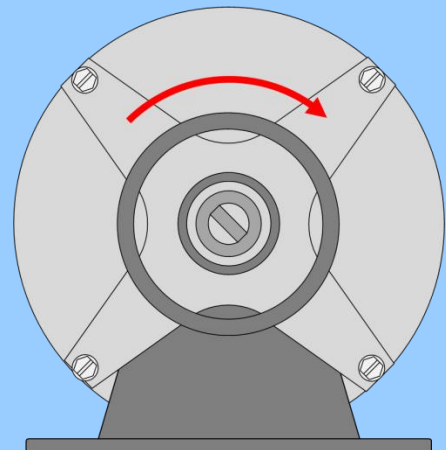

MOTOR MUST TURN CLOCKWISE AS
VIEWED FROM PUMP DRIVE SHAFT END

AB28 3 HP SINGLE PHASE 220V FMX PRE-WIRED BOX

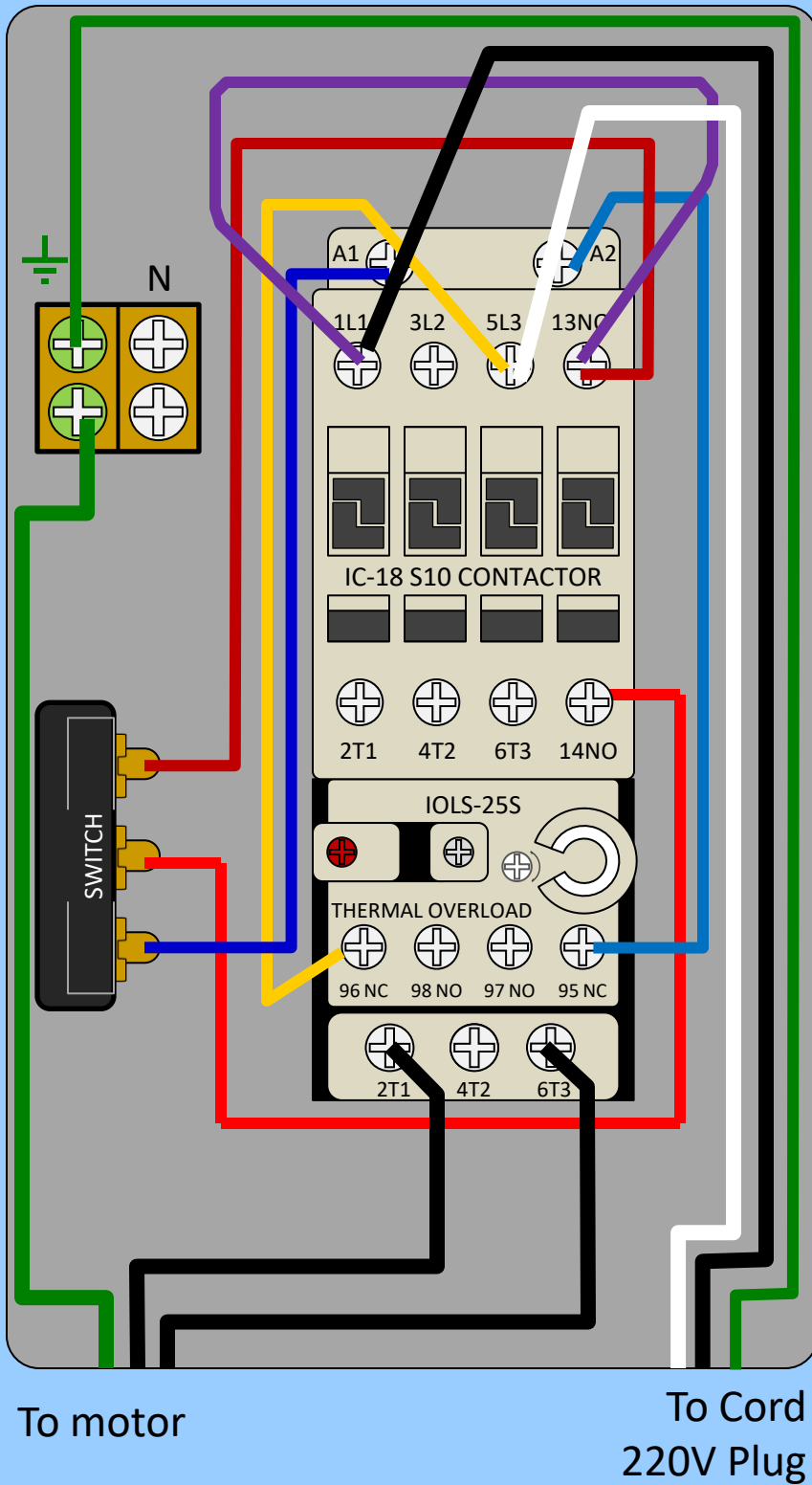

McDonnell & Miller FS1 Flow Switch

How it works:

The FS1 flow switch is a water flow sensing device. The switch is plumbed into the steam generator fresh water inlet line and wired into the steam generator circuitry. During operation, water pressure pushes a diaphragm that activates a magnet, which in turn makes or breaks a contactor. The switch completes the circuit when flow is present and breaks the circuit when there is no flow detected.

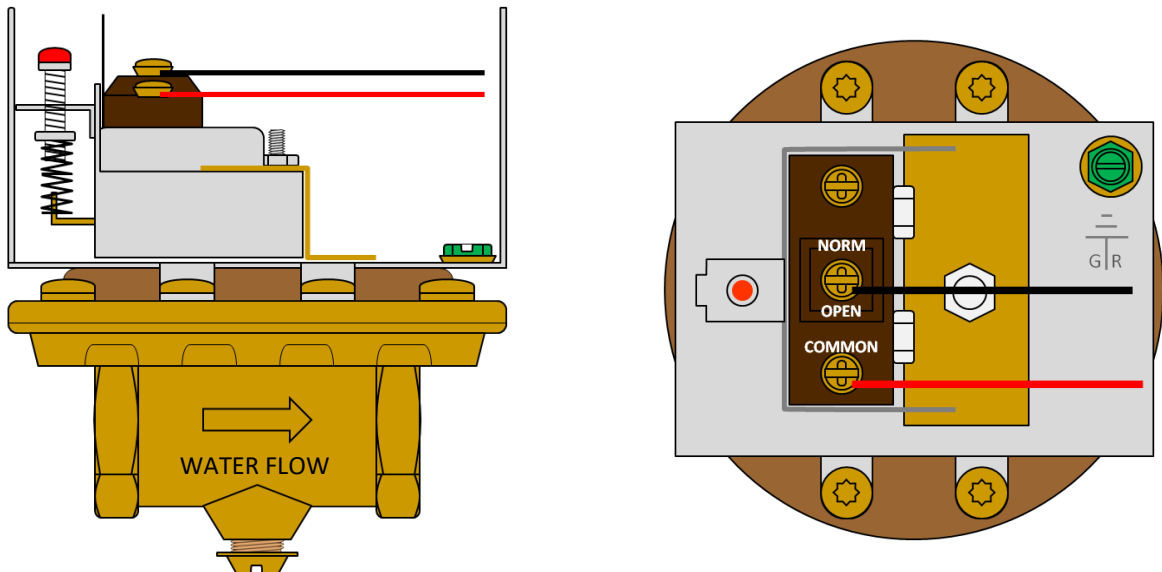

The **RED** wire is the hot lead from the control switch. When flow is present, the **BLACK** wire is energized and provides power to the primary control and green light.

McDonnell & Miller FS1 Flow Switch

Switch Adjustment and Troubleshooting

To gain access to the switch:

- Loosen 2 cover mount screws (1 each side)
- Remove vertical cover support (opposite conduit) by pulling the support out and up.
- Call Siebring Mfg. (888) 475-3317 for further instructions and troubleshooting advice.

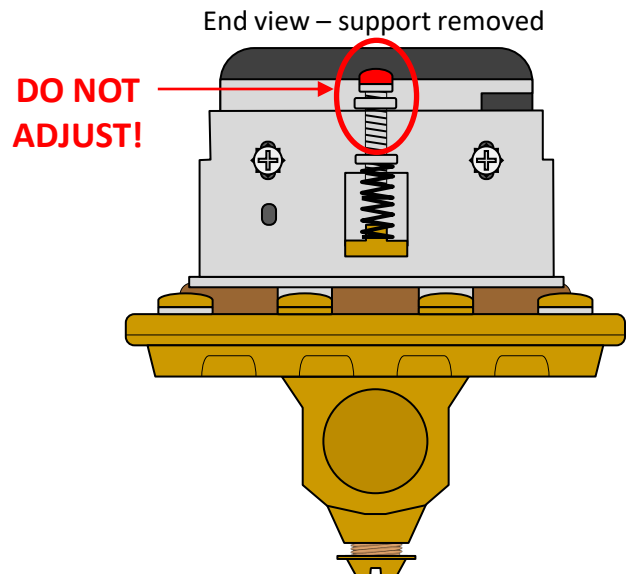
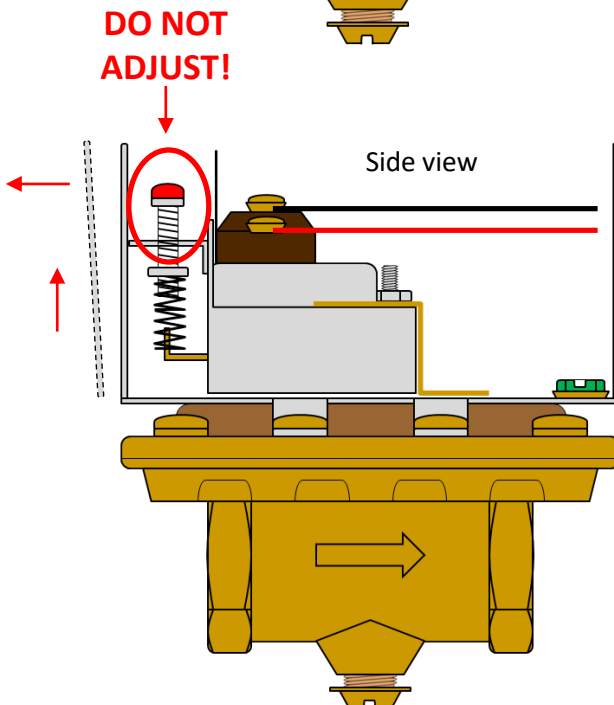
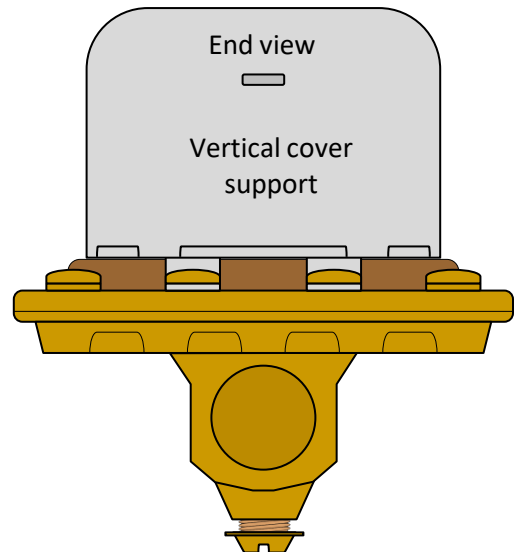
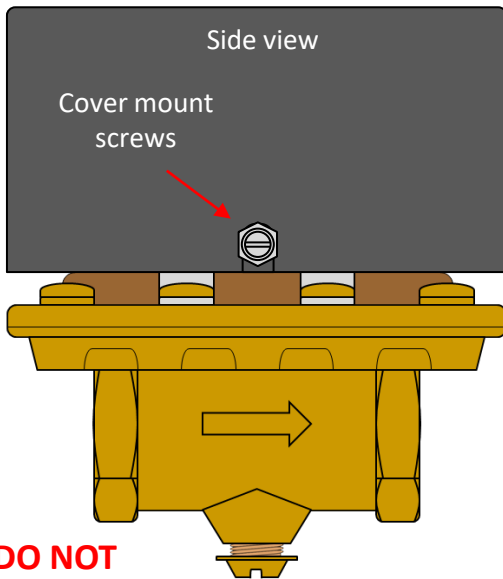

MEDIA HEATING SYSTEMS FOR FLORICULTURE AND NURSERY PRODUCTION

By

Robert A. Aldrich
Agricultural Engineer

INTRODUCTION—Floriculture and nursery growers using treated media in the production operation, heat with steam or apply chemicals for pest and disease control. Many recognize the advantages of treating soil using aerated steam where steam is mixed with exhaust air from a blower and then moved through the media. As the aerated steam moves, a warming front forms from condensing the water vapor out of the mixture onto the media particles. The temperature of the media cannot go higher than that of the aerated steam.

Treating with aerated steam can be done by a batch or continuous flow method. If mixing is required, either a rotating drum or auger type can be used successfully. Basic data have been developed for use in the design of casing heating systems.

MIXING—A rotating drum such as a transit concrete or masonry mortar mixer can be used to produce a satisfactory media if drum speed is adjusted to provide good tumbling action. The speed should be such that the material is carried well up the drum wall before tumbling. Satisfactory mixing can be obtained with from two to five minutes of mixing after the drum is loaded. Additional mixing will cause the particles to break up creating excess fines. Ball formation can be controlled by using relatively dry peat with a short mixing time. It is possible to heat in a rotating drum mixer and for best distribution, the saturated air (aerated steam) is delivered through a central pipe to a plenum in the bottom of the drum. The air leaves the plenum through a perforated cover and moves out through the tumbling media. A more efficient system is one which the drum is stopped and set in an upright position before heating is started. This reduces mixing time and increases fluid to media particle contact.

A rotating horizontal paddle or auger mixer such as a feed mixer will produce satisfactory media with rotational speeds between four and ten revolutions per minute. The tank should not be filled above two-thirds the auger diameter. If the tank is filled to the auger diameter, the top material will float and remain separate from the material lower in the tank.

The tank can be modified easily for in-tank heating. A slot approximately one-fourth the auger diameter is cut full length in the tank bottom. A double gate system is installed with a solid steel sliding gate for mixing and a perforated steel hinged gate for heating.

An operation using the same equipment for mixing and heating does not always make the most efficient use of time and energy in a complete media handling system because in such a system mixing and heating cannot be carried on simultaneously. A more efficient system is possible if the two activities take place in separate pieces of equipment. The mixer can be loaded and mixing done while the preceding batch is being heated. Media cooling can be done in the heating chamber or in a separate piece of equipment.

In a pot plant operation it may be convenient to have a continuous flow of treated media delivered to the potting line. This can be done in a batch heating system or in a continuous flow heating system. The continuous flow heater consists of a perforated or mesh belt in an insulated chamber with the aerated steam forced down through the media and belt such that contact time between air and media is at least one minute. An insulated holding bin or conveyor is necessary to keep the media at the treating temperature for 30 minutes to achieve pasteurization.

Each system, batch or continuous flow, should be designed and sized to fit the demands of the operation. If several materials are used as media, the equipment should be sized to satisfy the most severe requirements. Design calculations and equipment selection for two operations are illustrated in the following examples. The procedure can be used to size equipment for any operation once the operating specifications and system design data are set. Data on physical and thermal properties for several materials are given in Table 1. Psychrometric properties of saturated air are given in Table 2.

Table 1 Physical and Thermal Properties of Selected Media

Media	Dry Bulk Density (Lb./cu. ft.)	Average Particle Diameter (in.)	Moisture Content of A/3 ¹ (%)	Bulk Specific Heat (Btu/lb.-° F)	Particle Surface Heat Transfer Coef ² (Btu/ft. ² - hr.-° F)
Hagerstown silty clay loam	79	0.042	27	0.22	4.0
Mushroom soil	63	0.043	40	0.31	4.3
1:1:1 Mix Soil:peat:perlite	33	0.043	44	0.27	4.1
Spagnum moss peat, mushroom grade	6	0.020	690	0.47	N.A.
Spagnum moss peat, Hort. Grade	11	0.035	320	0.55	N.A.

¹ A/3 moisture content is defined as the moisture remaining in a soil originally saturated after being subjected to a tension of 1/3 atmosphere (A/3) atmosphere for 24 hours.

² Particle surface heat transfer coefficients given are averages from tests on media at near A/3 moisture content, depths ranging from 12 in. to 24 in., and an air flow rate of approximately 35 cu. ft. per minute per sq. ft. of gross area.

Table 2. Properties of Saturated Air (Aerated Steam) Mixtures. Air initially at 70° F, 50 % R.H., saturated steam at 230° F.

Mixture Temperature (° F)	Steam-Air Ratio (lb./ft. ³ of air*)	Heat Available (Btu/ft. ³ of air*)
140	0.01124	12.9
150	0.01574	18.1
160	0.0225	25.7
170	0.0318	37.3
180	0.0487	56.8

*Dry air at 70° F.

POT PLANT OPERATION

I. Operation Specifications

- A. Work scheduled to transplant 16,000 6" containers, in 8 hours working from 8 to 12 noon and from 1 to 5 p.m.
- B. Media to be 1:1:1 mix of soil:peat:perlite. Media to be at a temperature of 85° F or Lower when placed in the container.
- C. Containers to be delivered to transplanting stations.

II. System Design Data - General Data

- 1. Output = 81 cu. ft. per hour
- 2. Media weight = 33 lbs. per cu. ft., dry weight
- 3. Media moisture content = 40% on dry weight basis
- 4. Media specific heat = 0.27 BTU/lb.-° F
- 5. Heating temperature = 160° F
- 6. Media temperature = 60° F
- 7. Air temperature = 60° F
- 8. Media particle coefficient of heat transfer = 4.1 BTU/ft. ²-hr.-° F
- 9. Boiler to blower efficiency = 90%
- 10. Blower to media efficiency = 50%
- 11. Heat from saturated air at 160° F = 25.7 BTU/cu. ft.
- 12. Steam required to heat and saturate 70° F air = 0.0225 lb. per cu. ft.